

log Ladder Installation Guide

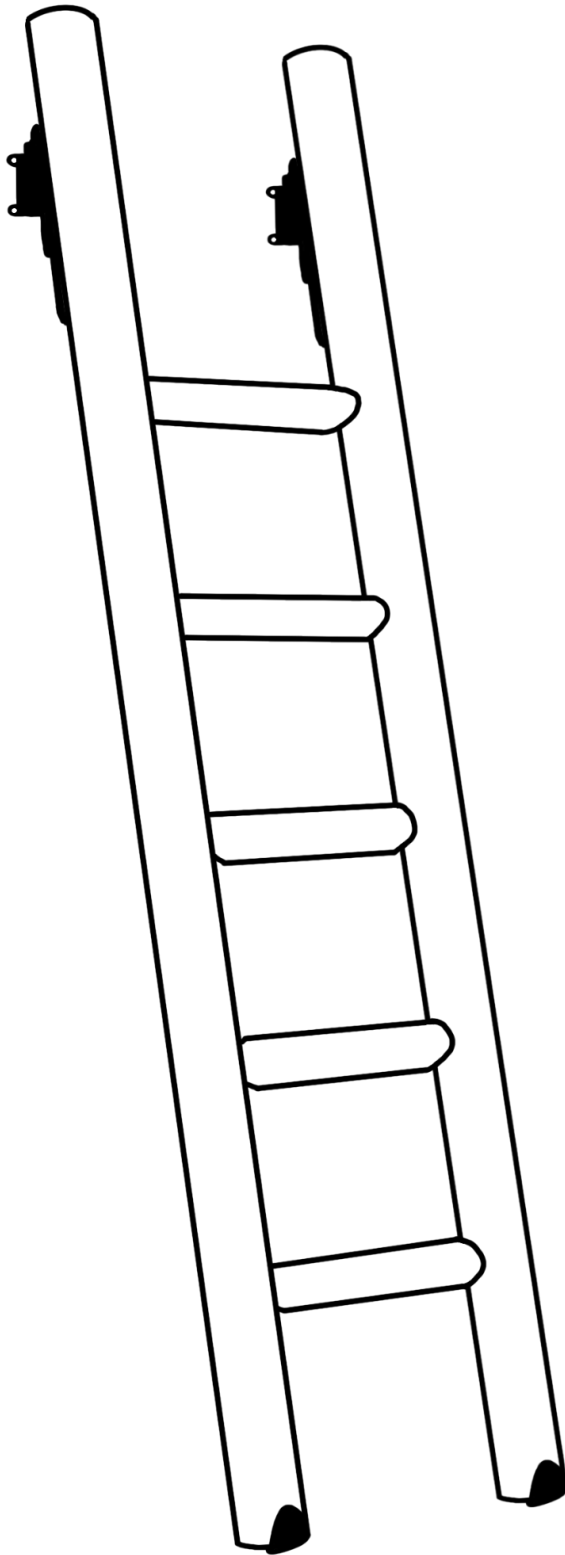

PUTNAM
ROLLING LADDER.

Necessary Tools:

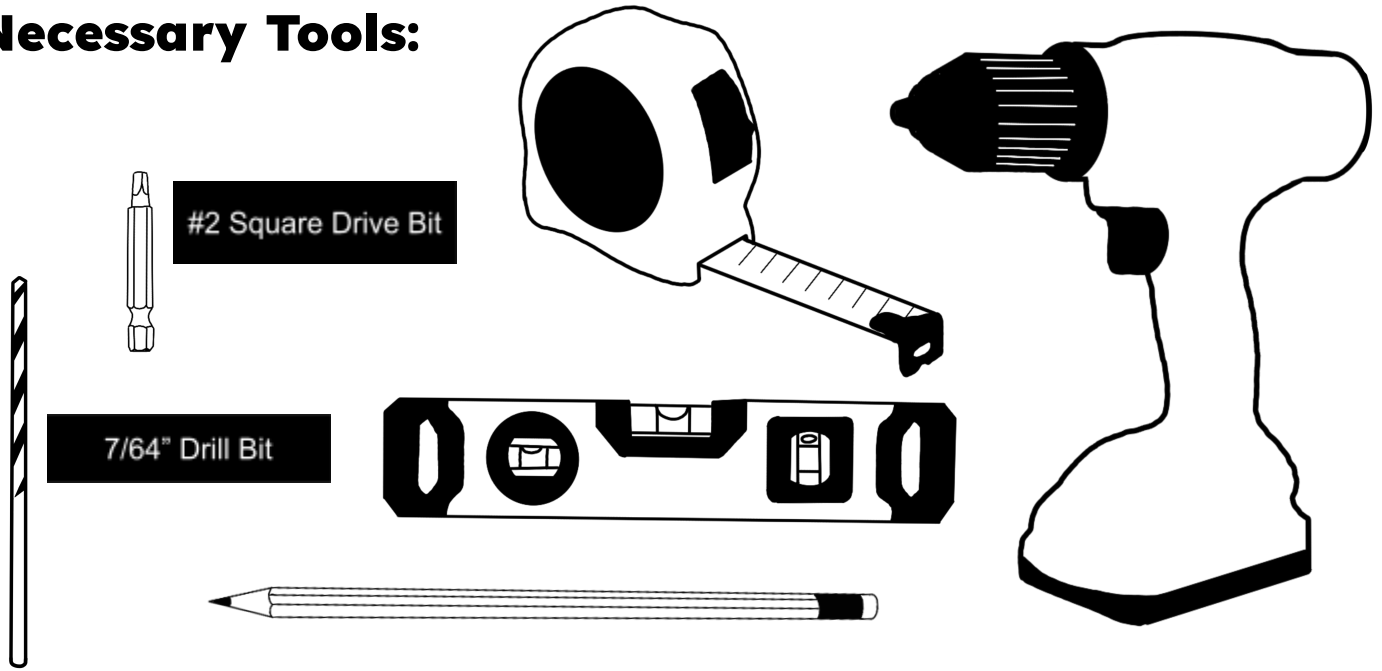

Provided:

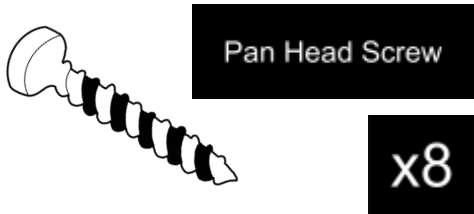

Safety Note:

Stationary loft ladder and hardware will enable users to access a loft area. To ensure users can get into and come back down from the loft safely, install mounting hardware firmly to the railing posts/supports on either side of the opening.

Dimensions:

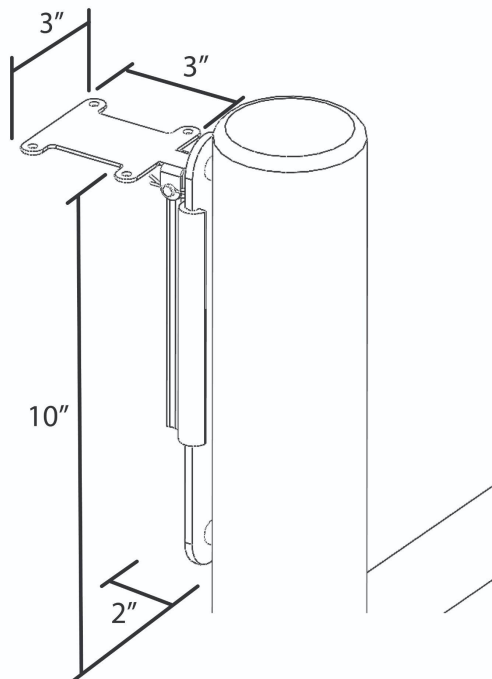

Installation Guide for Log Ladder

1. Align the ladder in the stored position in front of the loft opening ensuring the brackets are all the way down. (Figure 1) Notice: The Flat Plate should be fastened to solid wood. A header board should be installed if needed. Scribe a level line on the header board along the bottom of the Flat Plate. (Figure 2)

Note: If the loft floor edge protrudes more than 1 inch beyond the vertical surface of the header board, place the bottom of the Flat Plate 3-1/2" down from the bottom of the protruding loft floor.

Figure 1

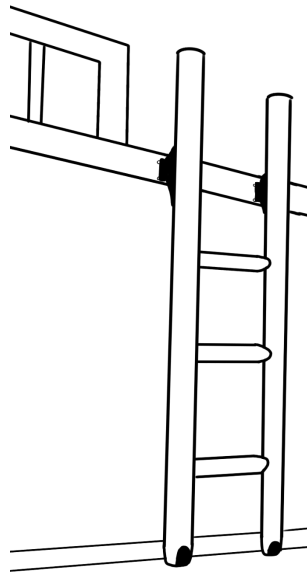
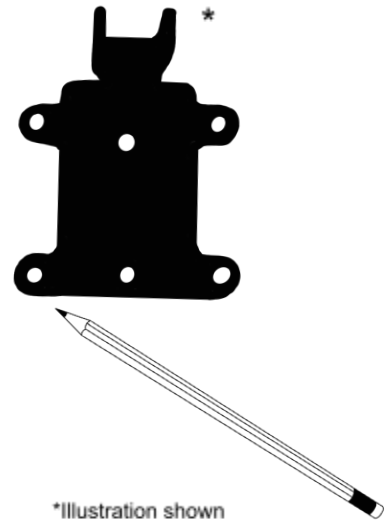

Figure 2

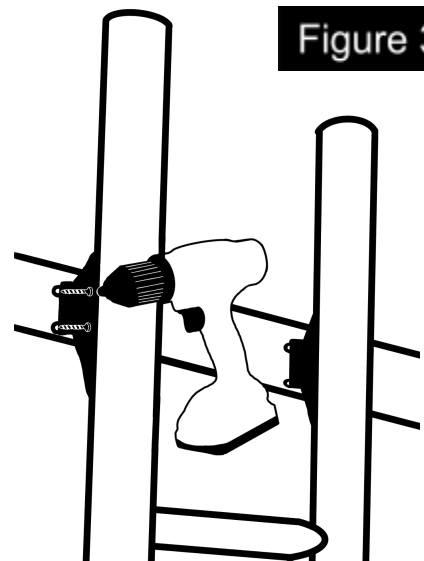

*Illustration shown to depict the bottom of Flat Plate, do not remove hardware from the ladder.

2. Using all 8 of the supplied #10 x 3/4" pan-head screws, install the Flat Plate hardware directly into solid wood. Be sure to position the bottom of the Flat Plate along the scribed line on the header board. Use all eight (8) included screws. (Figure 3)

Congratulations on Installing your Log Ladder!

Figure 3



Questions on installation?
Please email service@cshardware.com
or call **(800) 882-0009** M-F 8:00am-4:30pm CST